



M37531T-ADS

Temporary Target Board for M37531RSS, M37532RSS, M37534RSS,
M37536RSS, M37540RSS, M37542RSS, M37544RSS

User's Manual

Keep safety first in your circuit designs!

- Renesas Technology Corporation and Renesas Solutions Corporation put the maximum effort into making semiconductor products better and more reliable, but there is always the possibility that trouble may occur with them. Trouble with semiconductors may lead to personal injury, fire or property damage. Remember to give due consideration to safety when making your circuit designs, with appropriate measures such as (i) placement of substitutive, auxiliary circuits, (ii) use of nonflammable material or (iii) prevention against any malfunction or mishap.

Notes regarding these materials

- These materials are intended as a reference to assist our customers in the selection of the Renesas Technology product best suited to the customer's application; they do not convey any license under any intellectual property rights, or any other rights, belonging to Renesas Technology Corporation, Renesas Solutions Corporation or a third party.
- Renesas Technology Corporation and Renesas Solutions Corporation assume no responsibility for any damage, or infringement of any third-party's rights, originating in the use of any product data, diagrams, charts, programs, algorithms, or circuit application examples contained in these materials.
- All information contained in these materials, including product data, diagrams, charts, programs and algorithms represents information on products at the time of publication of these materials, and are subject to change by Renesas Technology Corporation and Renesas Solutions Corporation without notice due to product improvements or other reasons. It is therefore recommended that customers contact Renesas Technology Corporation, Renesas Solutions Corporation or an authorized Renesas Technology product distributor for the latest product information before purchasing a product listed herein. The information described here may contain technical inaccuracies or typographical errors. Renesas Technology Corporation and Renesas Solutions Corporation assume no responsibility for any damage, liability, or other loss rising from these inaccuracies or errors. Please also pay attention to information published by Renesas Technology Corporation and Renesas Solutions Corporation by various means, including the Renesas home page (<http://www.renesas.com>).
- When using any or all of the information contained in these materials, including product data, diagrams, charts, programs, and algorithms, please be sure to evaluate all information as a total system before making a final decision on the applicability of the information and products. Renesas Technology Corporation and Renesas Solutions Corporation assume no responsibility for any damage, liability or other loss resulting from the information contained herein.
- Renesas Technology semiconductors are not designed or manufactured for use in a device or system that is used under circumstances in which human life is potentially at stake. Please contact Renesas Technology Corporation, Renesas Solutions Corporation or an authorized Renesas Technology product distributor when considering the use of a product contained herein for any specific purposes, such as apparatus or systems for transportation, vehicular, medical, aerospace, nuclear, or undersea repeater use.
- The prior written approval of Renesas Technology Corporation and Renesas Solutions Corporation is necessary to reprint or reproduce in whole or in part these materials.
- If these products or technologies are subject to the Japanese export control restrictions, they must be exported under a license from the Japanese government and cannot be imported into a country other than the approved destination. Any diversion or reexport contrary to the export control laws and regulations of Japan and/or the country of destination is prohibited.
- Please contact Renesas Technology Corporation or Renesas Solutions Corporation for further details on these materials or the products contained therein.

Precautions to be taken when using this product

- This product is a development supporting unit for use in your program development and evaluation stages. In mass-producing your program you have finished developing, be sure to make a judgment on your own risk that it can be put to practical use by performing integration test, evaluation, or some experiment else.
- In no event shall Renesas Solutions Corporation be liable for any consequence arising from the use of this product.
- Renesas Solutions Corporation strives to renovate or provide a workaround for product malfunction at some charge or without charge. However, this does not necessarily mean that Renesas Solutions Corporation guarantees the renovation or the provision under any circumstances.
- This product has been developed by assuming its use for program development and evaluation in laboratories. Therefore, it does not fall under the application of Electrical Appliance and Material Safety Law and protection against electromagnetic interference when used in Japan.

For inquiries about the contents of this document or product, fill in the text file the installer of the emulator debugger generates in the following directory and email to your local distributor.

\\SUPPORT\Product-name\SUPPORT.TXT

Renesas Tools Homepage <http://www.renesas.com/en/tools>

Contents

1. Things to Check When Unpacking	4
2. Outline	4
3. Specifications	4
4. Setting Up	5
5. Oscillator Circuit	7
5.1 Oscillator Circuit Board	7
5.2 Using the CR Oscillator Circuit Pattern	8
6. Pin Layout	9

1. Things to Check When Unpacking

The M37531T-ADS package consists of the following products. When unpacking your package, check to see that all of these components are included.

Table 1.1 Package components

Temporary target board	M37531T-ADS
User's manual	M37531T-ADS User's manual (this manual)

* If you find any item missing or faulty, or any suggestion, contact your local distributor.

2. Outline

The M37531T-ADS is a temporary target board used to develop software with a PC4701 emulator system. It supplies to the emulator MCU the minimum required signals needed to operate the 7531/7532/7534/7536/7540/7542/7544 Group RSS MCUs, including power supply voltage, clock signals and reset signals. Use it when the target system is not ready.

3. Specifications

Table 3.1 lists specifications of the M37531T-ADS.

Table 3.1 Specifications of the M37531T-ADS

Applicable MCU	M37531RSS M37532RSS M37534RSS M37536RSS M37540RSS M37542RSS M37544RSS	
Clock	4.0MHz oscillator mounted (oscillator circuit board OSC-2 used)	
Vcc	Supplied separately*	
Vss	Supplied separately*	
RESET	<ul style="list-style-type: none">Reset circuit mounted (power-on reset and reset switch)Connects the reset output of an emulation pod	
External dimensions	Width	90 mm
	Depth	115 mm
Others	<ul style="list-style-type: none">Pattern for CR oscillator preparedUniversal part prepared	

* Power cannot be supplied from the emulation pod for PC4701 (e.g. M38000TL2-FPD). A separate power supply is needed.

4. Setting Up

This chapter describes how to set up the M37531T-ADS.

- (1) Mount an emulator MCU on the M37531T-ADS. After checking the position of the No. 1 pin of the emulator MCU, mount the emulator MCU.

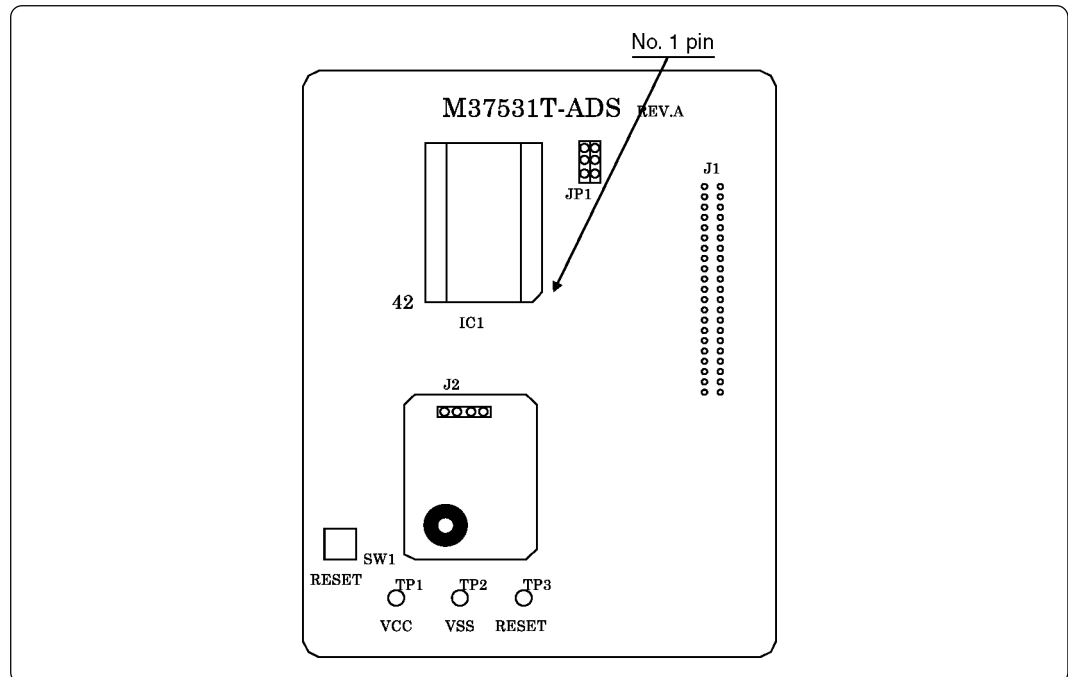

Figure 4.1 Position of No. 1 pin of an M37531T-ADS's emulator MCU

- (2) Connect the white cable and black cable of the emulation pod to RESET pin (TP3) and Vss pin (TP2) of the M37531T-ADS respectively.
- (3) Connect a power supply (not included) to Vcc pin of the M37531T-ADS. And connect the GND output of the power supply to Vss pin.
- (4) **Do not connect the yellow cable of the emulation pod to Vcc pin (TP1).**

Tables 4.1 lists the correspondence of the connector cables and signals, and Figure 4.2 shows the connection.

Table 4.1 Connector cables of the M38000TL2-FPD and applicable signals

Cable color	Signal
White	RESET
Black	Vss
Yellow	Vcc (no connection)

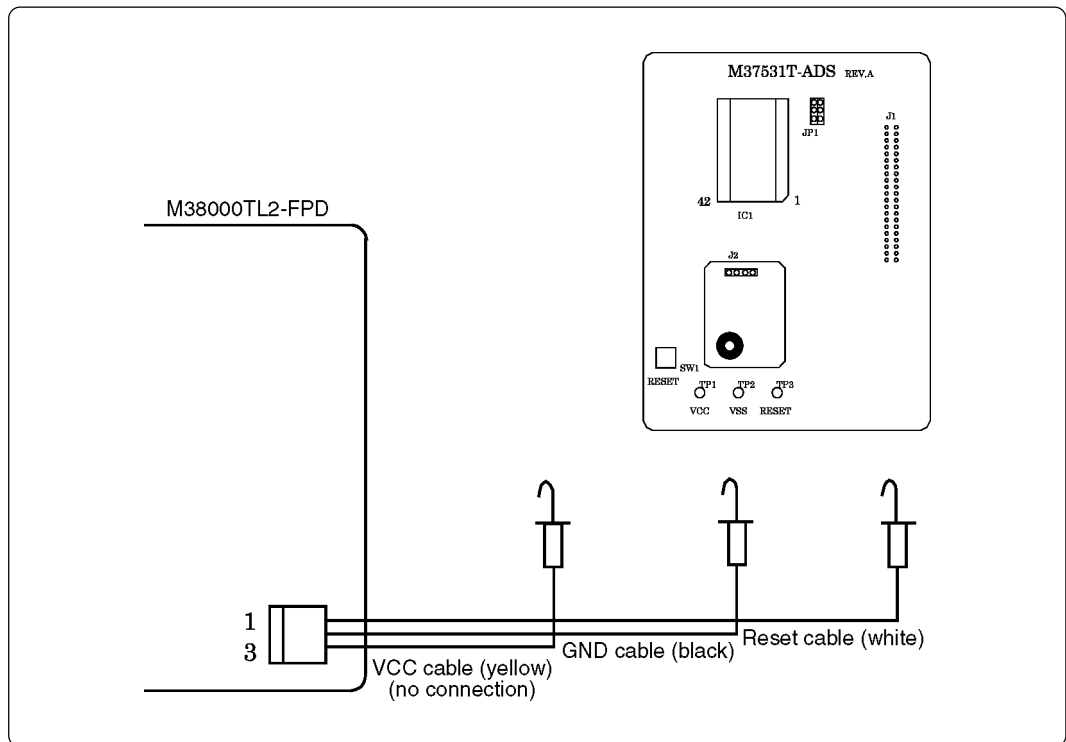

Figure 4.2 Connecting the M37531T-ADS

CAUTION

Note on Setting Up:

- Always shut OFF power before connecting this product. The power ON state could destroy internal circuits.

5. Oscillator Circuit

5.1 Oscillator Circuit Board

The M37531T-ADS has a built-in oscillator circuit board on which a 4.0MHz oscillator is mounted.

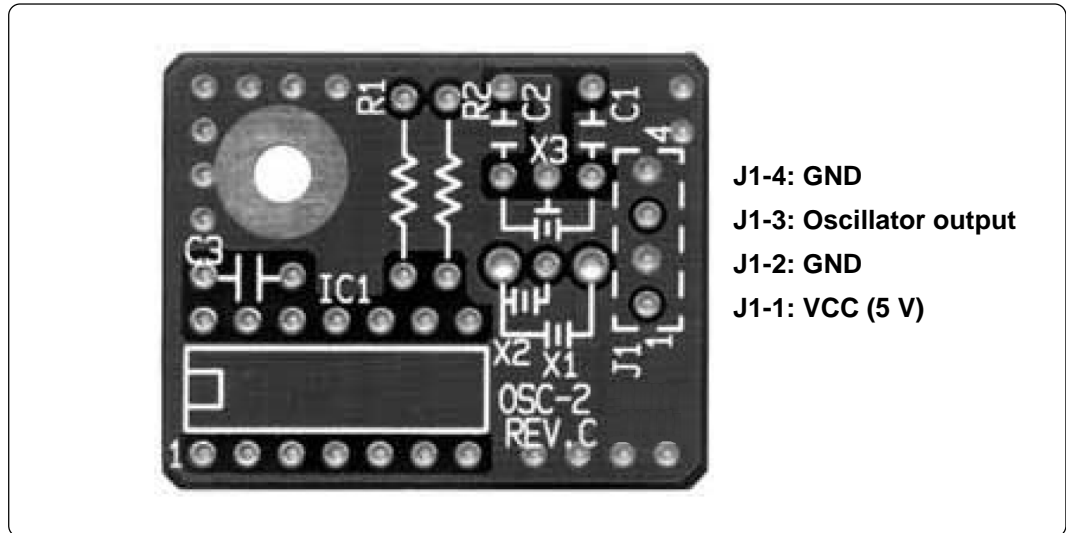

Figure 5.1 External view of the oscillator board (OSC-2) and connector pin assignment

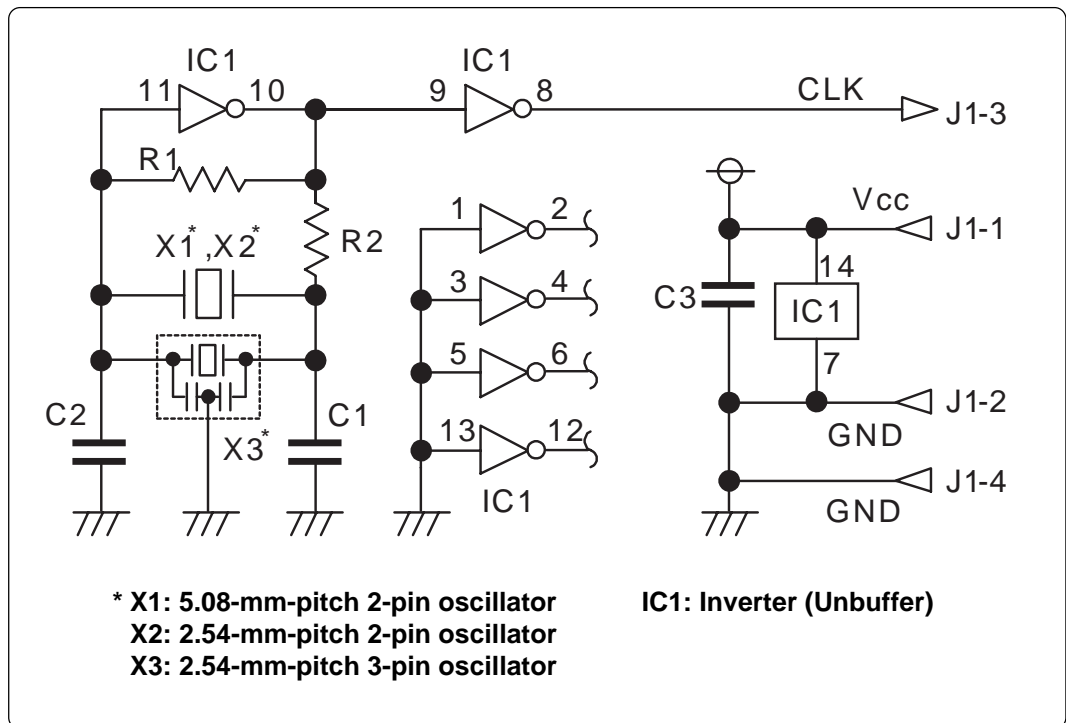

Figure 5.2 Circuit of the oscillator board (OSC-2)

5.2 Using the CR Oscillator Circuit Pattern

There is a CR oscillator circuit pattern on the M37531T-ADS.

To use the CR oscillator circuit pattern, mount R3 and C5, and remove the coated wire of JP1, then change the setting.

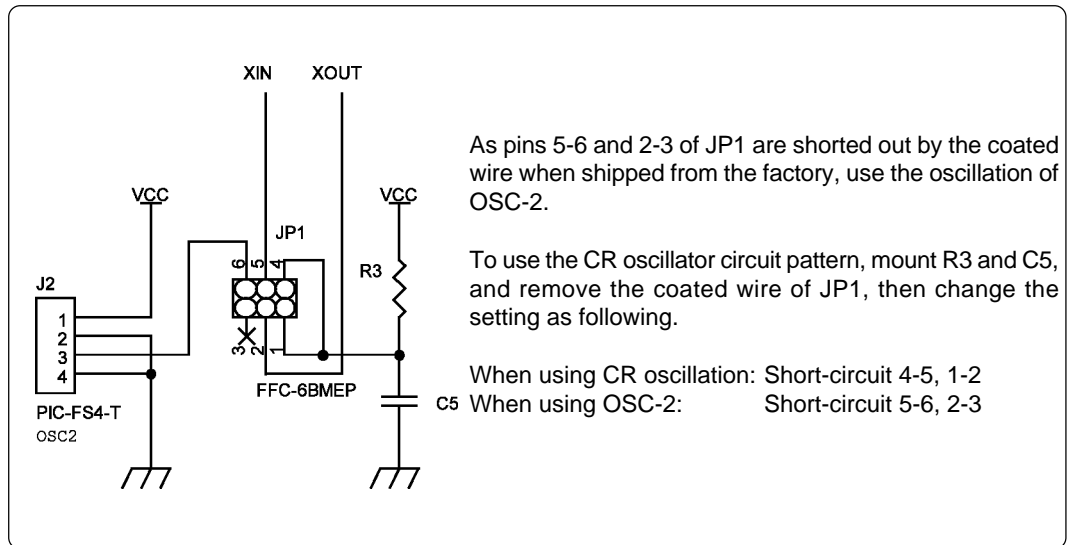

Figure 5.3 Using the CR oscillator circuit pattern

CAUTION

Note on Setting Up:

- Always shut OFF power before connecting this product. The power ON state could destroy internal circuits.

6. Pin Layout

Figure 6.1 shows the pin layout of the M37531T-ADS.

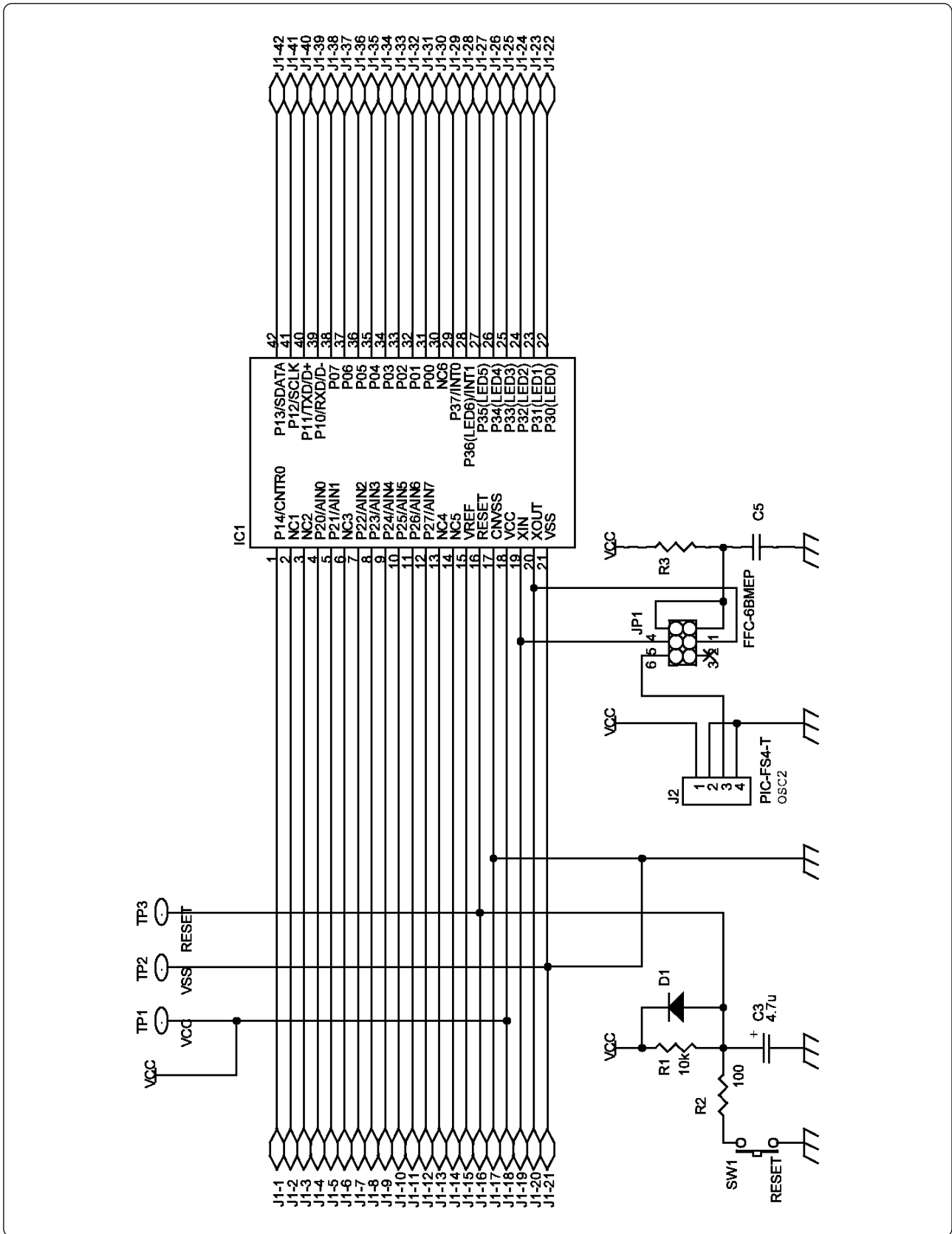

Figure 7.1 Pin layout of the M37531T-ADS

MEMO

M37531T-ADS User's Manual

Rev.1.00
September 1, 2003
REJ10J0367-0100Z

COPYRIGHT ©2003 RENESAS TECHNOLOGY CORPORATION
AND RENESAS SOLUTIONS CORPORATION ALL RIGHTS RESERVED



RenesasTechnology Corp.

2-6-2, Ote-machi, Chiyoda-ku, Tokyo, 100-0004, Japan